

CTS 3001 Evaluation Kit

User Manual

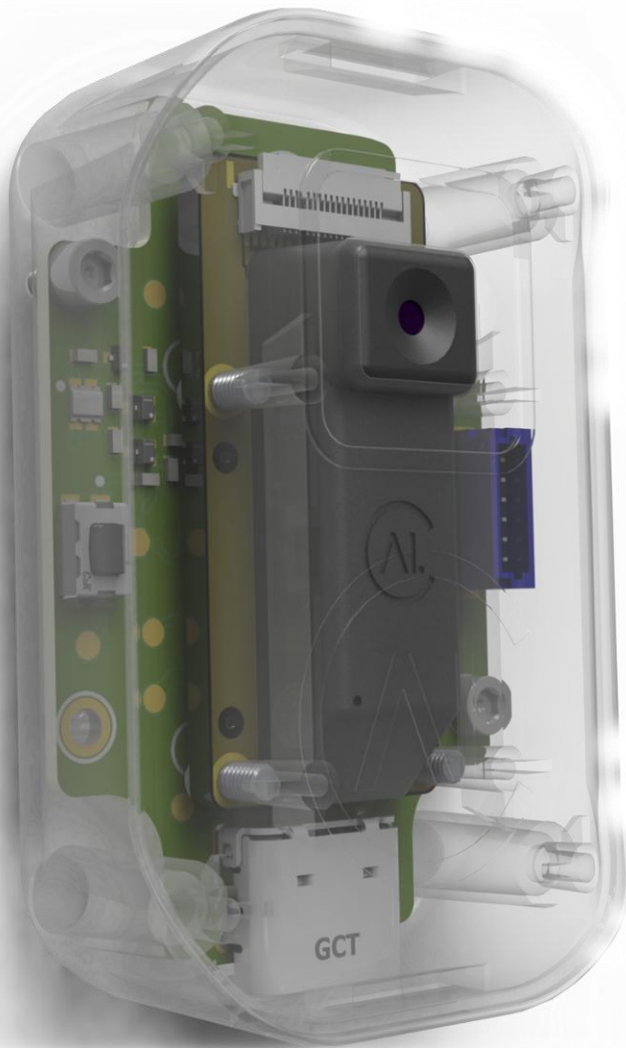

Table of Contents

Introduction.....	3
1 Quick Setup Guide	4
2 Download Software and Drivers	5
3 CTS Player	6
4 Raw Thermal Tab in CTS Player.....	10
5 Computer Vision (CV) tab in CTS Player.....	13
6 Regions of Interest tab in CTS Player.....	18
7 About tab in CTS Player	20
8 Metadata tab in CTS Player	21
9 Utilities	22
10 Commercial Real Estate (CRE) Applications.....	24
11 Performing Commercial Real Estate Application Evaluation	28
12 Industrial Monitoring Evaluation	29
13 Troubleshooting Guide.....	31
14 Revision History.....	33

Introduction

Congratulations on your purchase of the CTS3001 Evaluation Kit (EVK), and welcome to Calumino! This evaluation kit will aid in determining if the Calumino Thermal Sensor (CTS) is correct for your applications. Please follow this guide carefully to help you get up and running with the EVK.

Handling Instructions

The thermal sensor incorporates precision-engineered cantilevered mirrors. While the sensor is designed to withstand standard handling, care should be taken to avoid excessive shock or impact, which may affect its operational integrity. To ensure the device maintains its calibration accuracy and continues performing optimally, ensure it is handled with care.

Software Pre-requisites:

The CTS Player and EVK are designed only to be operated with **Windows 10/11** operating systems.

The following are general recommendations for using the EVK connected to a Windows PC/laptop:

- If the CTS Player is installed on a laptop, please ensure that the computer remains plugged into power throughout the entire time you are using the CTS Player.
- The CTS Player has been tested on Windows 10 up to version 21H2.

1 Quick Setup Guide

The steps below can be followed to get the EVK up and running.

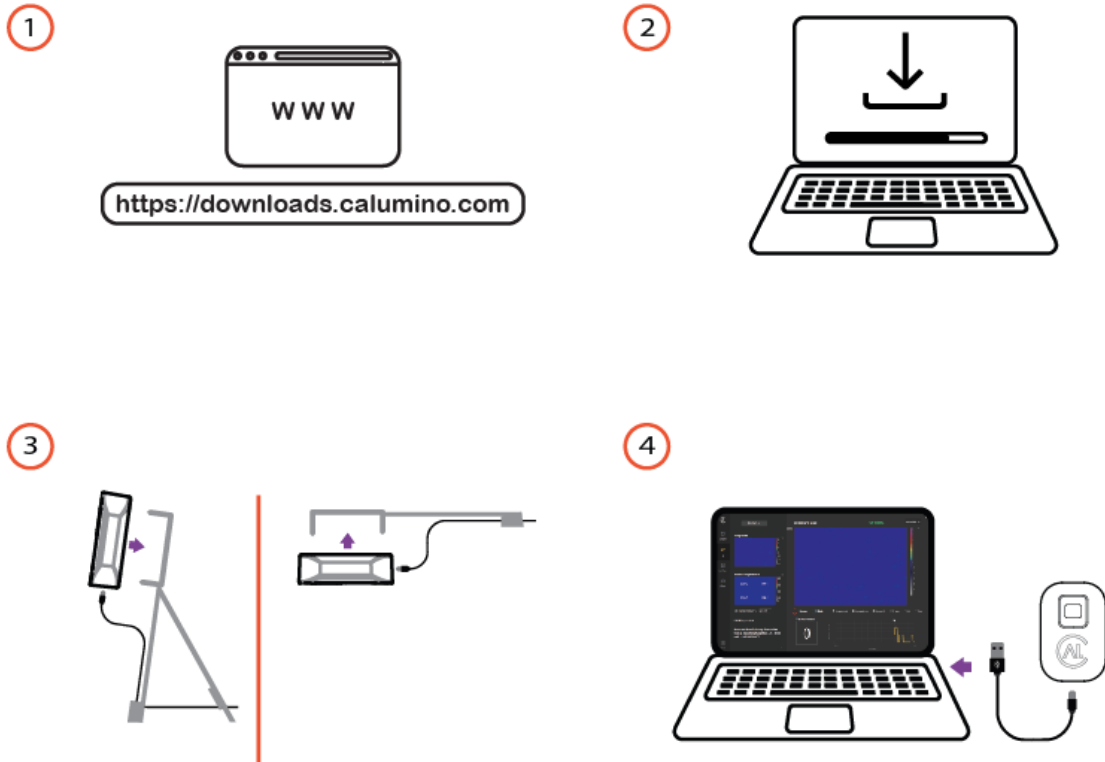

1. Navigate to <https://downloads.calumino.com> and download the latest version of the CTS Player using the credentials provided to you by Calumino.
2. Install the software by unzipping/extracting the downloaded folder and running the setup.exe executable.
3. Install the EVK on either the tripod or ceiling:
 - a. Tripod (provided): Best for asset monitoring applications. Press the two components of the tripod together, feeding the USB cable through both legs before plugging into the EVK.
 - b. Ceiling: Best for people detection and counting applications. Connect the front leg of the tripod to the ceiling using a screw through the countersunk hole, or by using the adhesive strips provided. Ensure the cable clip (provided) is used to prevent the weight of the cable pulling the EVK from the ceiling.
4. Plug the USB-A into the computer and open CTS Player.

2 Download Software and Drivers

This section describes how to download and install the CTS Player and required drivers.

2.1 Download software

2.1.1 Please go to <https://downloads.calumino.com/>.

2.1.2 Log in with the credentials provided.

2.1.3 From the above webpage, download the CTS Player. (note: current versions may differ slightly)

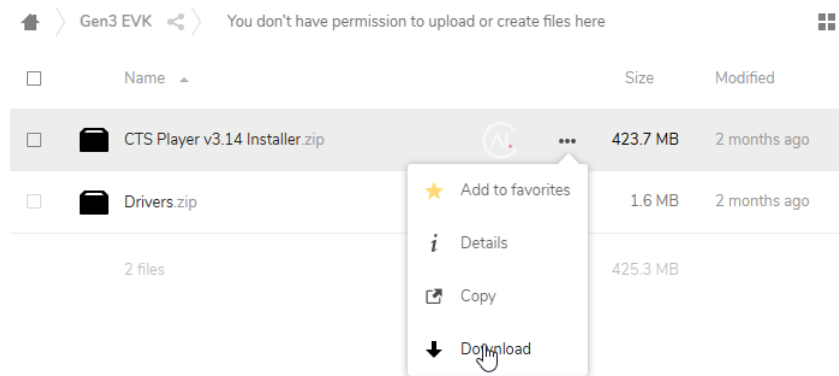

Figure 1 - Downloading CTS Player from the Downloads Portal

2.1.4 Downloading can be achieved by right-clicking on the desired folder and selecting 'Download' from the dropdown menu.

3 CTS Player

3.1 Installation

- 3.1.1 Please unzip/extract the downloaded installer zip file.
- 3.1.2 Open the unzipped folder and execute the setup.exe file in this folder. This is done by right-clicking on “setup.exe” and selecting “Run as Administrator”. A User Account window may pop up; press “Yes”. This will execute the software installation process of the CTS Player and its dependencies.

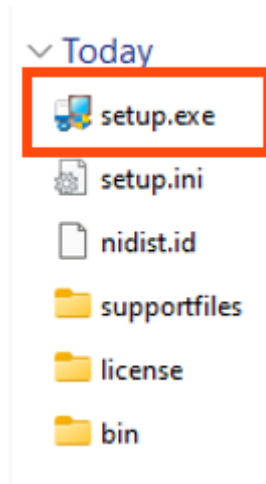

Figure 2 - Installer Folder contents after being extracted

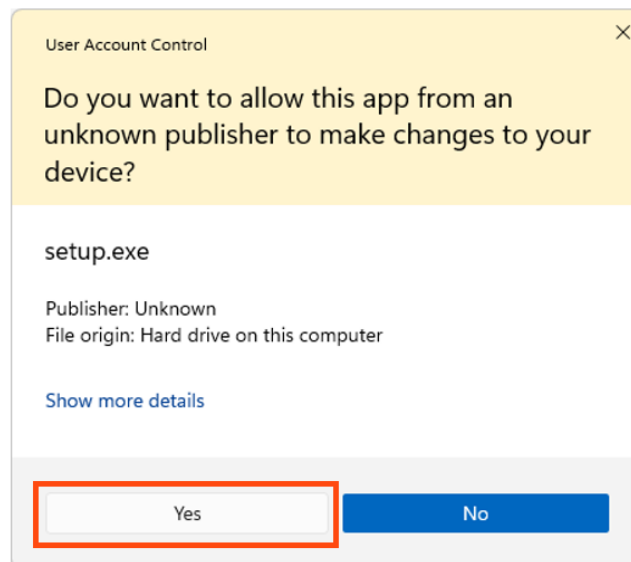

Figure 3 - User Account Control Pop-up

- 3.1.3 CTS Player installation process:

- Windows Defender may ask you if you want to run the installation. Press “More info” followed by “Run anyway”

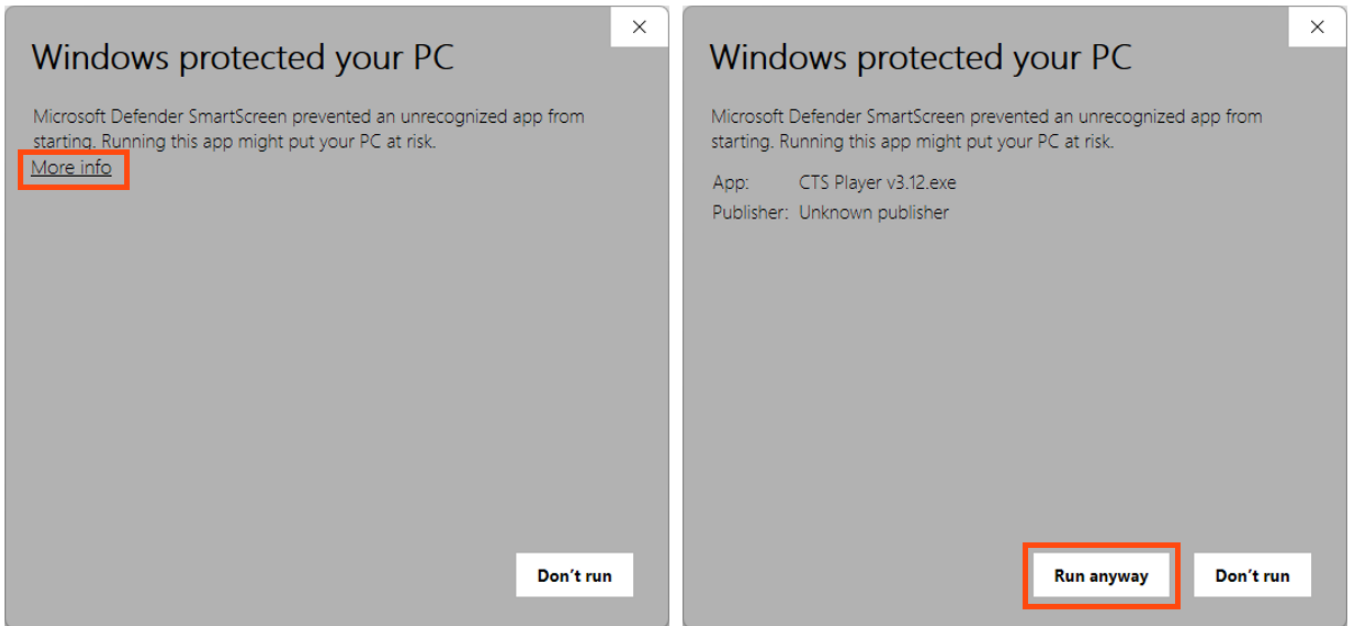

Figure 4 - Microsoft Defender window

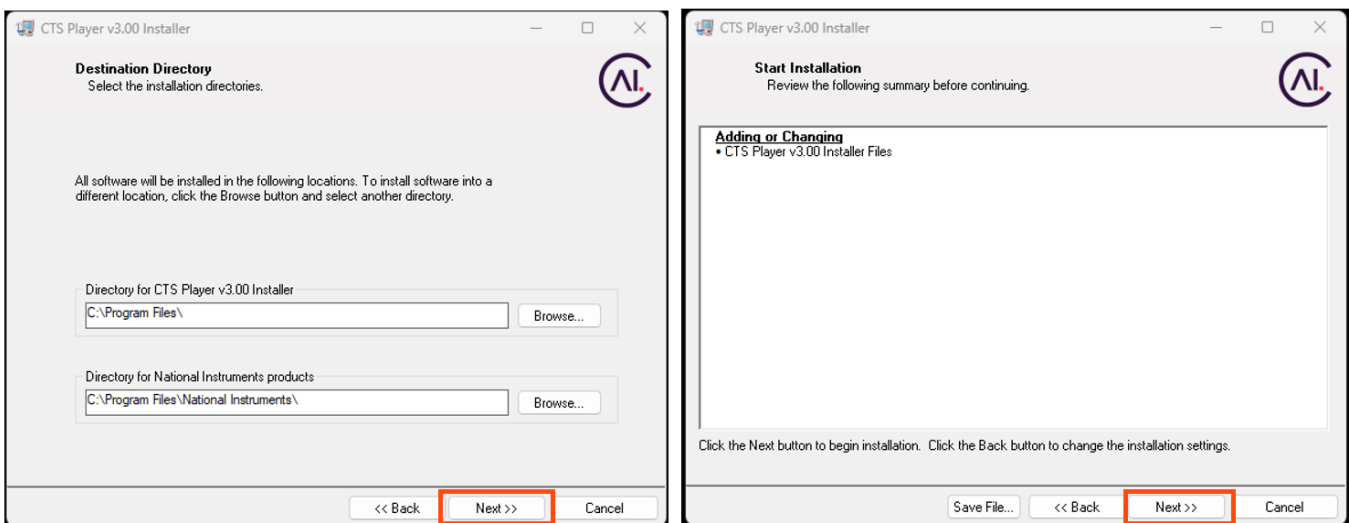

Figure 5 - CTS Player Installer Progress

3.1.3.1 Press “Next >>” through the installation windows.

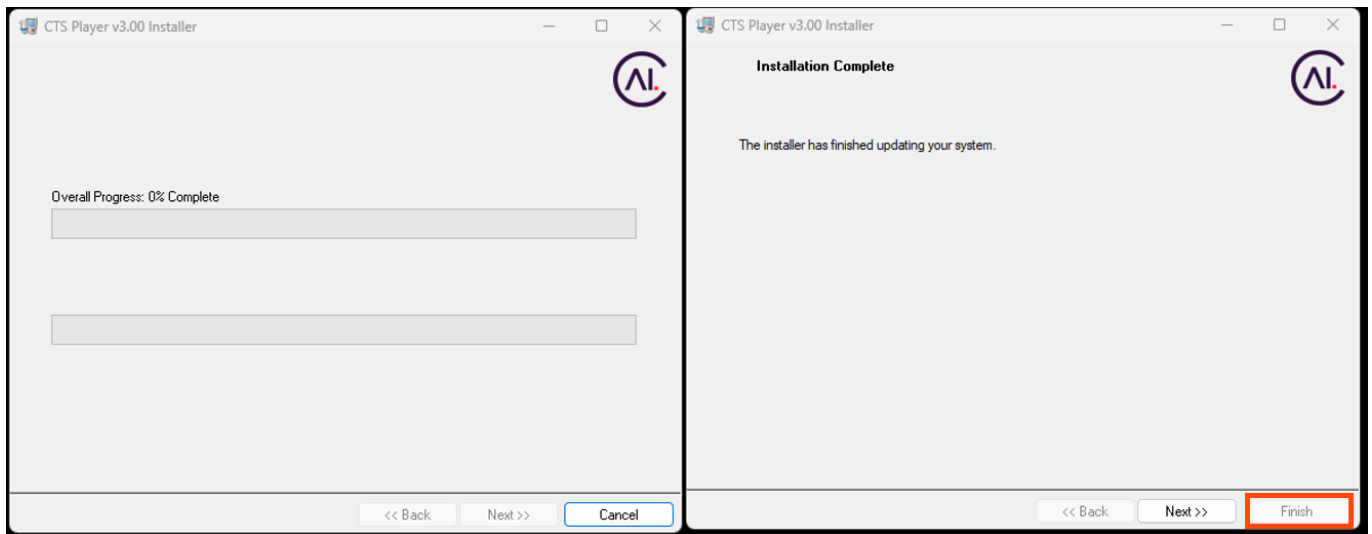

Figure 6 - Beginning and End of the CTS Player Installation process

- Once the “Installation Complete” window appears, press “Finish”.

After completion of the setup, the user will be asked to restart the computer, this is a requirement to successfully proceed to the next steps.

3.2 Check if drivers are installed:

- 3.2.1 Once installation is complete and the computer has been restarted, please connect the EVK to a PC/laptop using the USB cable provided with the EVK.
- 3.2.2 Open the device manager on your PC/laptop (by pressing the Windows key and typing "device manager") and check if the following ports appear on it.

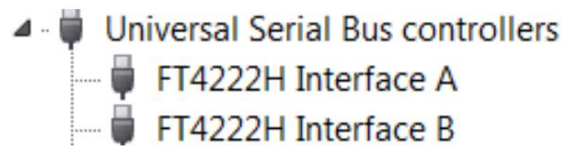

Figure 7 – Device Manager with correct drivers installed

- 3.2.3 If these drivers are installed, please proceed to Section "3.3 - Operating CTS Player". If not, please follow the steps below.
- 3.2.4 Install Missing Drivers (if necessary)
 - Download the missing drivers by downloading the "Drivers" folder from the downloads portal.
 - Click on the downloaded file to open it in Windows File Explorer. Extract the files from the .zip file, right-click on the ftdibus.inf file and click 'Install'. Repeat this process for ftdiport.inf.
 - A confirmation window will appear if the installation is successful.
 - Now, when opening Device Manager, your device should show FT4222H Interfaces under 'Universal Serial Bus Controllers'; see Figure 7.

3.3 Operating CTS Player

- 3.3.1 Once successfully restarted, please launch the CTS Player program using the desktop shortcut or from the install directory.
- 3.3.2 The CTS player is capable of visualising one EVK at any given time. If you have multiple units connected to your computer at once, upon opening CTS Player you will be prompted to choose between the available units passed on their COM port number.

4 Raw Thermal Tab in CTS Player

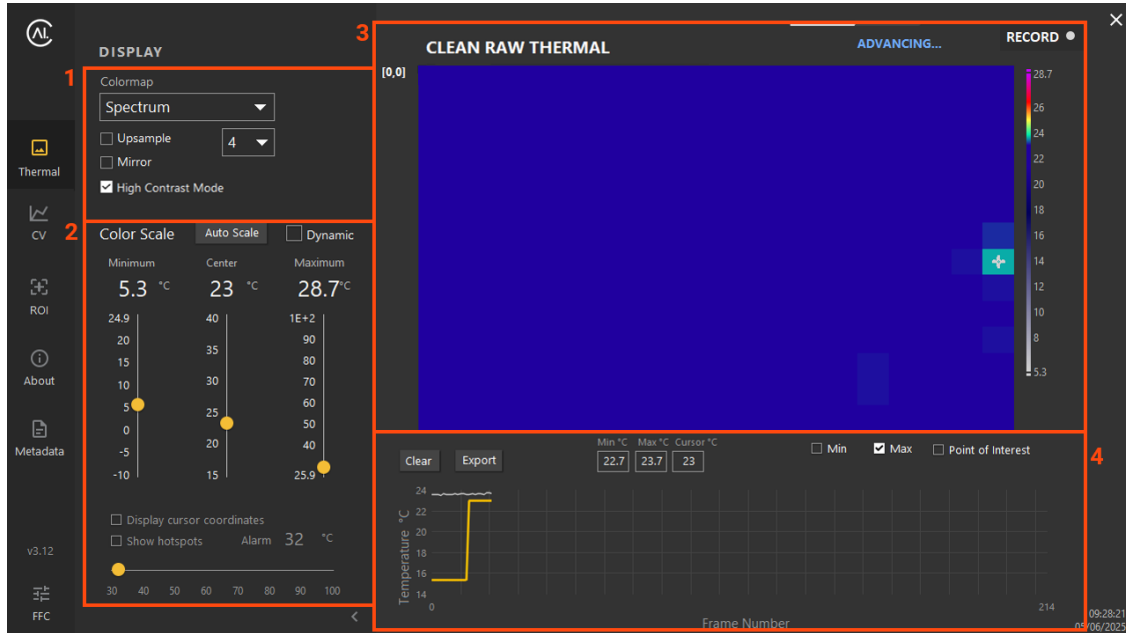

Figure 8 - Thermal tab in CTS Player

The thermal tab contains the raw thermal output from the EVK.

4.1 Menu 1: General Visualisation Options

Selection	Detail
Drop down Colormap list	Allows a choice of color visualisation in the displayed thermal data. (Spectrum by default)
Upsample Toggle	When toggled, allows the user to select between upsampling the thermal data 2 or 4 times (Using the dropdown menu). Upsampling increases the <i>perceived</i> resolution
Mirror	Mirrors the visualisation about a vertical line
High contrast mode	Toggle to enable high-contrast mode. This reduces visual noise in the thermal image

4.2 Menu 2: Thermal Visualisation Options

Selection	Detail
Temperature display sliders	Three sliders for setting the Minimum, Centre and Maximum points for the colour scale (Seen on the right of the thermal image)
Auto scale	Quick scale reset for optimal visualisation.
Dynamic color scaling	Toggle the automatic adjustment of the scale on or off.
Location information	Toggle to display the coordinates of the cursor.
Hotspot detection	Select to show a bounding box around areas at, or above, the Alarm temperature.
Manual alarm temperature setting	Input the desired alarm temperature.
Quick alarm temperature setting	Slider for simpler alarm temperature setting.
Hotspot detection	Toggle on to highlight areas above the alarm/slider temperature.

4.3 Menu 3: Thermal Data Visualisation

Live view display of CTS captured scenery, including indicators for maximum, minimum, and moveable cursor locations. Also included is the ability to record the thermal view to allow for playback within the CTS playback app (this shows the real temperature output recorded rather than the relative temperature scale shown previously)

4.4 Menu 4: Graphical visualisation

Graphical visualisation of temperature data and ability to export the data captured. There are options to toggle an automatic cursor at the location of the minimum and the maximum as well as a toggle for a placeable cursor (point of interest).

Selection	Detail
Clear	Button to clear the current plot.
Export	Button to export the data being plotted to a csv.
Min value	The minimum temperature value seen in the live display.
Max value	The maximum temperature value seen in the live display.
Point of Interest	The temperature value at the location of the Point of Interest. When enabled, Point of Interest initially located in the centre of the FOV and can be dragged around the thermal display.
Min, Max and Point of Interest toggle	Toggle each of the indicators on and off.
Plot	A plot of the values which have been toggled on.

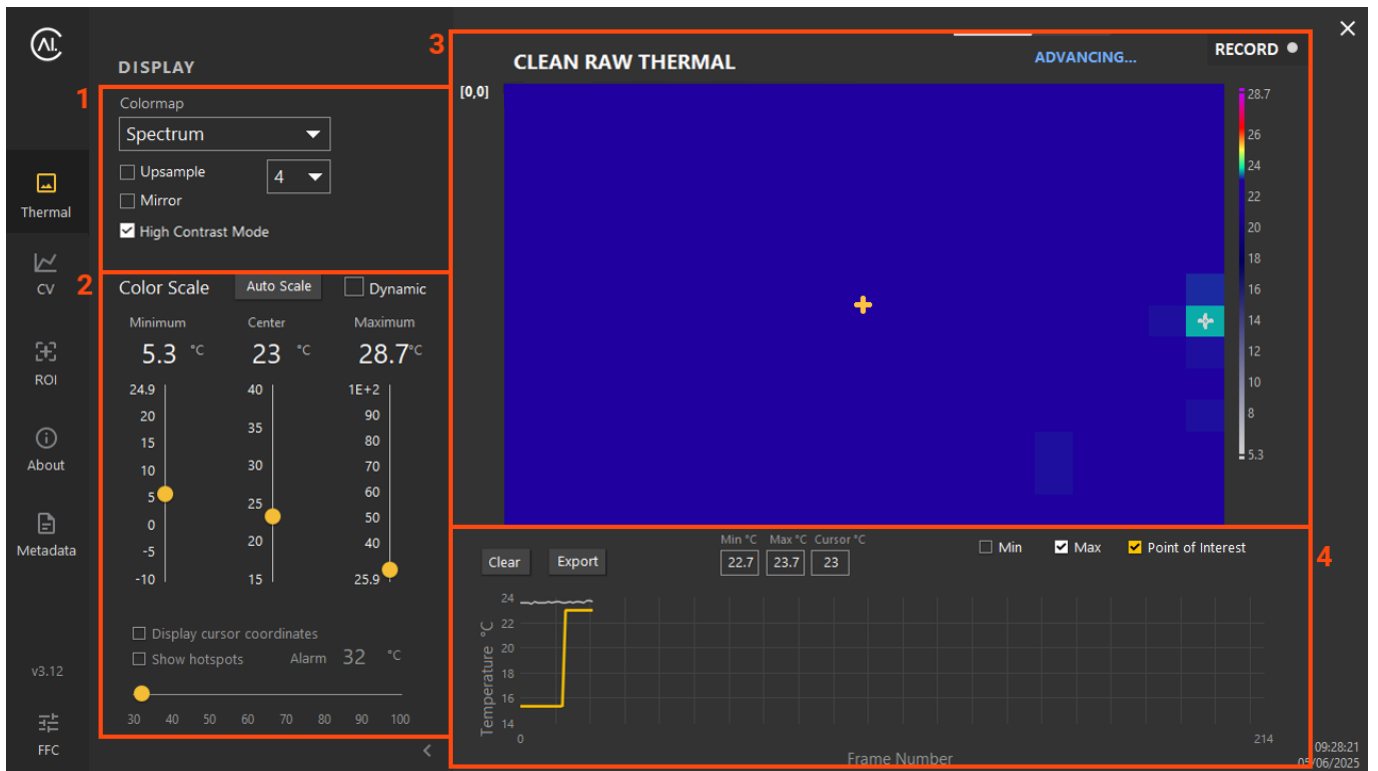

Figure 9 - Thermal Tab with the Point of Interest Enabled

5 Computer Vision (CV) tab in CTS Player

Note: The Computer Vision (CV) tab will not visualise any data for the first 240 frames (approximately 60s) upon powering the EVK. Ideally, the FOV should remain empty until the CV has initialised.

Important:

Please ensure that the EVK has been mounted to a ceiling at 2.5m height before evaluating the computer vision. The computer vision is optimised for 2.5m and has been designed to detect people from a top-down perspective.

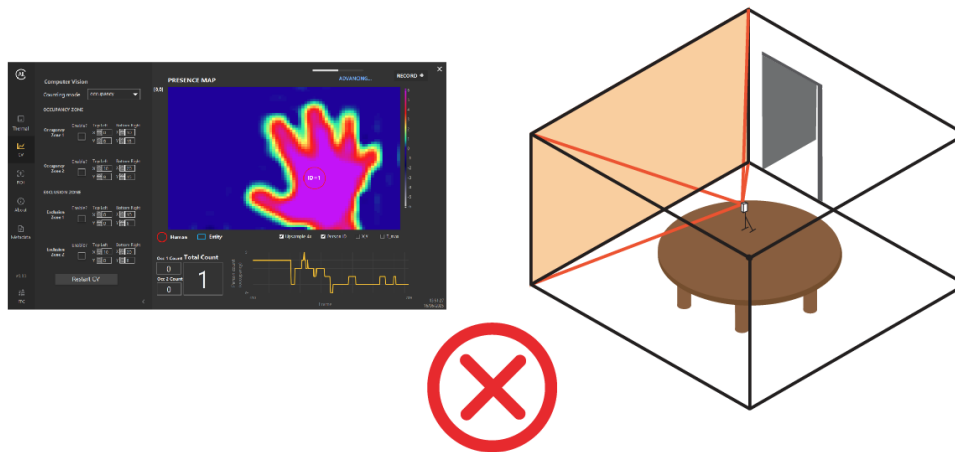

Figure 10 - Computer vision designed to work in top-down configuration only

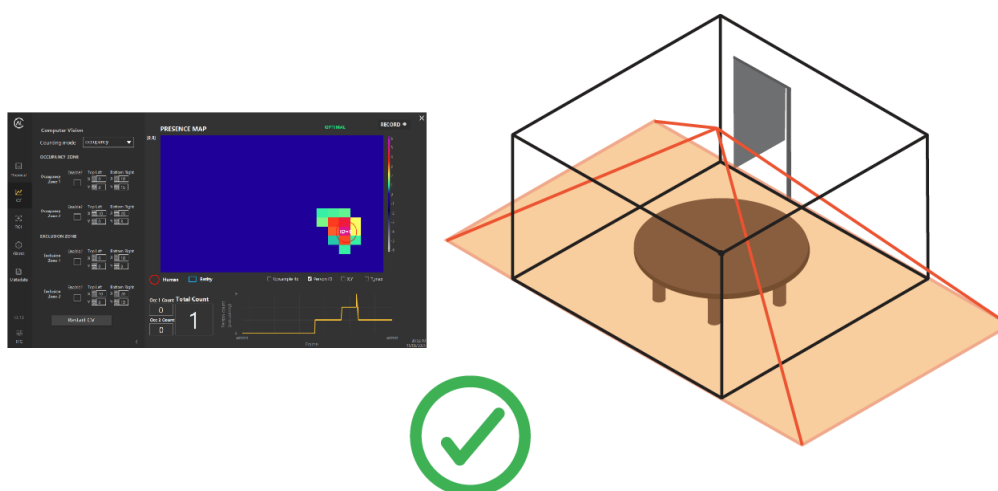

Figure 11 - Correct output from Computer Vision in top-down configuration

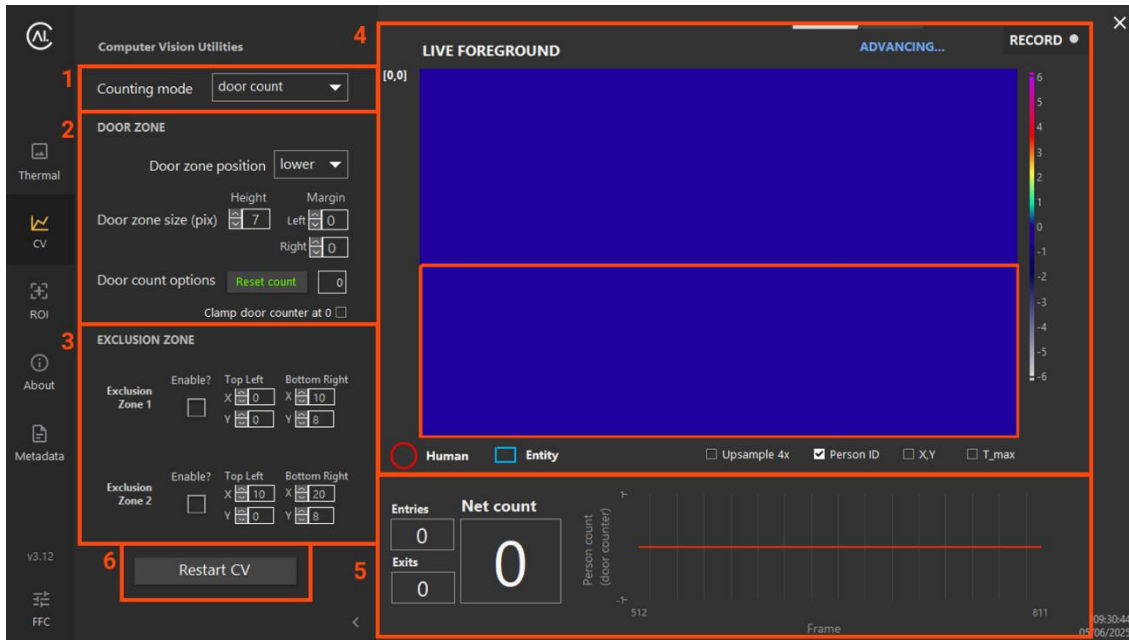

Figure 12 - CV tab in CTS Player (Door Counting Mode)

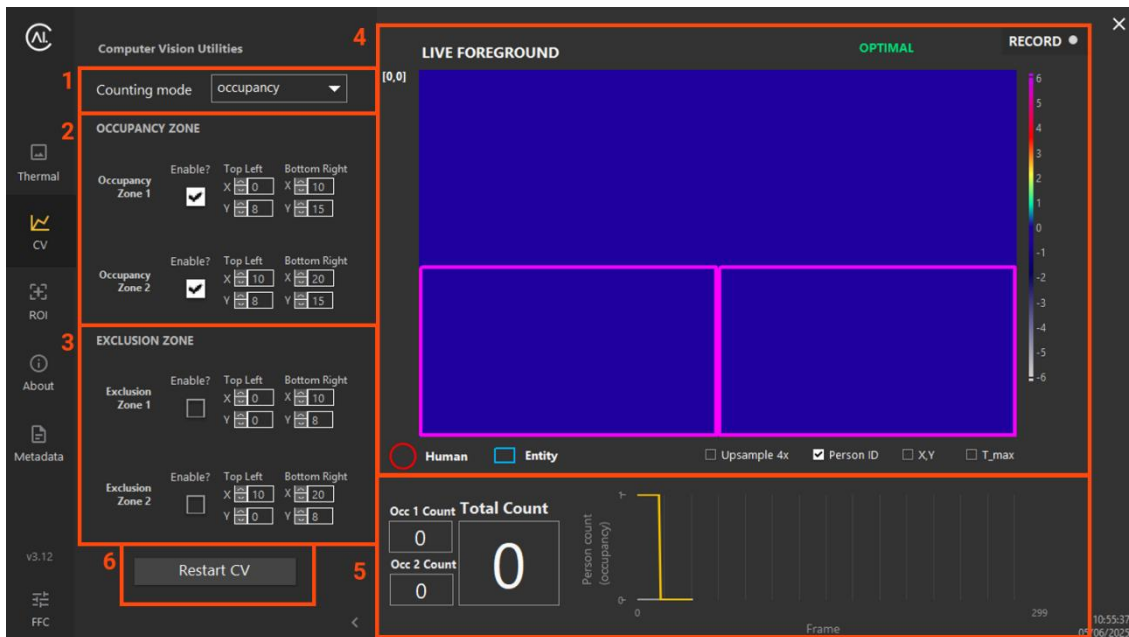

Figure 13 - CV tab in CTS Player (Occupancy Mode)

5.1 Menu 1: Computer Vision Utility Selection

Options to select door counting or occupancy mode via a dropdown menu.

Counting Mode: Occupancy	Application to count the number of people in the Field of View (FOV)
Counting Mode: Door count	Application to count numbers of people crossing through a rectangular sub-section of the FOV.

5.2 Menu 2: Occupancy or Door Counting Configuration

Door Counting Mode:

Door zone position	Door zone position can be set to the upper or lower portion of the field of view.
Door zone size	Size can be adjusted in depth and margin size. It is recommended to user a door zone with a width of at least 5 pixels when the device is installed 1.2-1.5m from the doorframe.
Reset count	Reset the door count (back to zero) or set a value manually.
Clamp door counter at 0	Toggle to prevent the door count from becoming negative.

Occupancy Mode

Occupancy Zone Enable	Toggle to enable the zones
Position adjustment for the top left and bottom right pixel of each zone.	The zones are drawn as a rectangle between the top left and bottom right pixels. Increasing the X will move it towards the right in the display, and increasing the Y will move it down. (Top left is 0,0 with x being the horizontal axis)

5.3 Menu 3: Exclusion Zones

Applies to both Door Counting and Occupancy Modes

Exclusion Zone Enable	Toggle to enable the zones
Adjustment for the top left and bottom right pixel of the zones.	The zones are drawn as a rectangle between the top left and bottom right pixels. Increasing the X will move it towards the right in the display, and increasing the Y will move it down. (Top left is 0,0 with x being the horizontal axis)

5.4 Menu 4: Live Foreground Visualisation

Applies to both Door Counting and Occupancy Modes

Key for Humans and Entities/Blobs	Red circles denote a human, blue rectangle for objects
Up-sample toggle	Toggle the display between standard and up-sampled
Person ID display	Toggle to display or hide from the display
Person X,Y location display	Toggle to display or hide from the display
Maximum temperature of the humans in the FOV	Toggle to display or hide from the display
Record	Functionality that allows the user to record the outputs of the CV and saves the data into the folder "CTS Data" on the desktop.

5.5 Menu 5: Graphical Visualisation

Door Counting Mode

Entries	Number of entries (Entering the FOV via the door zone)
Exits	Number of exits (Exiting the FOV via the door zone)
Net Count	Number of Entries minus the number of Exits
Plot	Graphical representation of the Net count over time

Occupancy Mode

Occ 1 Count	Number of people currently in Occupancy zone 1
Occ 2 Count	Number of people currently in Occupancy zone 2
Total Count	The total number of people detected in the entire FOV
Plot	Graphical representation of the Total Count over time.

5.6 Menu 6: Restart CV

The CV can be restarted to create a new empty reference frame. This must be done when the scene is empty and will be used as a reference to detect when people move into the scene.

A CV reset should be done when the EVK is installed in the ceiling of a new room and is used for people counting.

To enable the technician to remove themselves from the room, there is an option to set a delay (in seconds) to count down before the restart takes effect.

Do not unplug the EVK while restarting the CV.

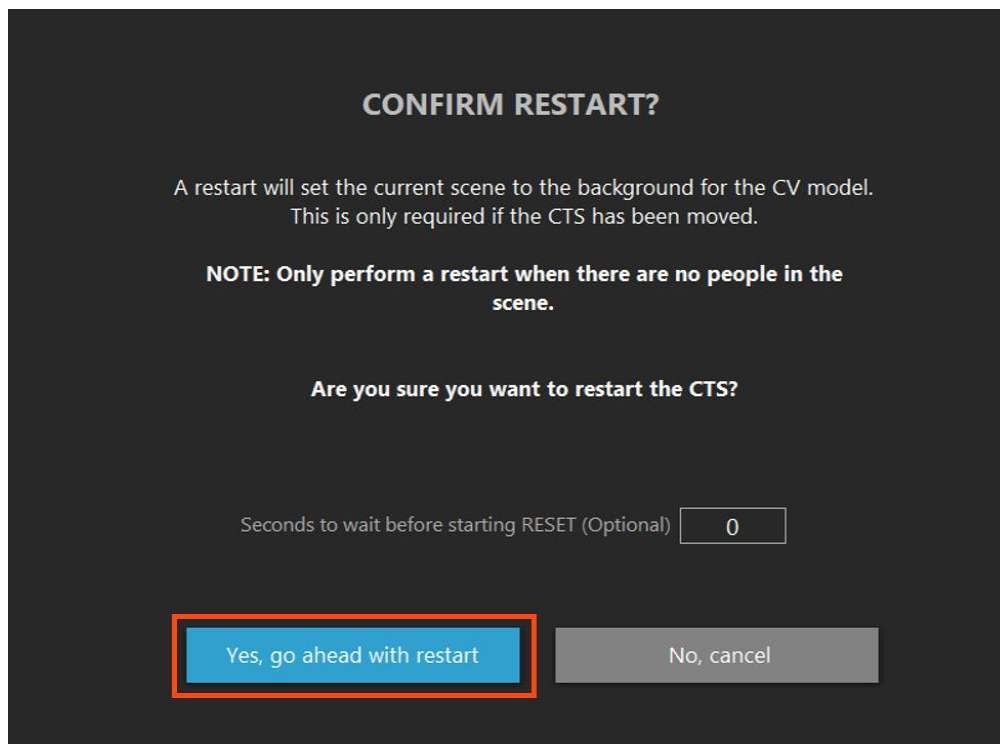

Figure 14 - Restart CV confirmation window

6 Regions of Interest tab in CTS Player

The ROI Tab allows for evaluation of the CTS as an asset monitoring device.

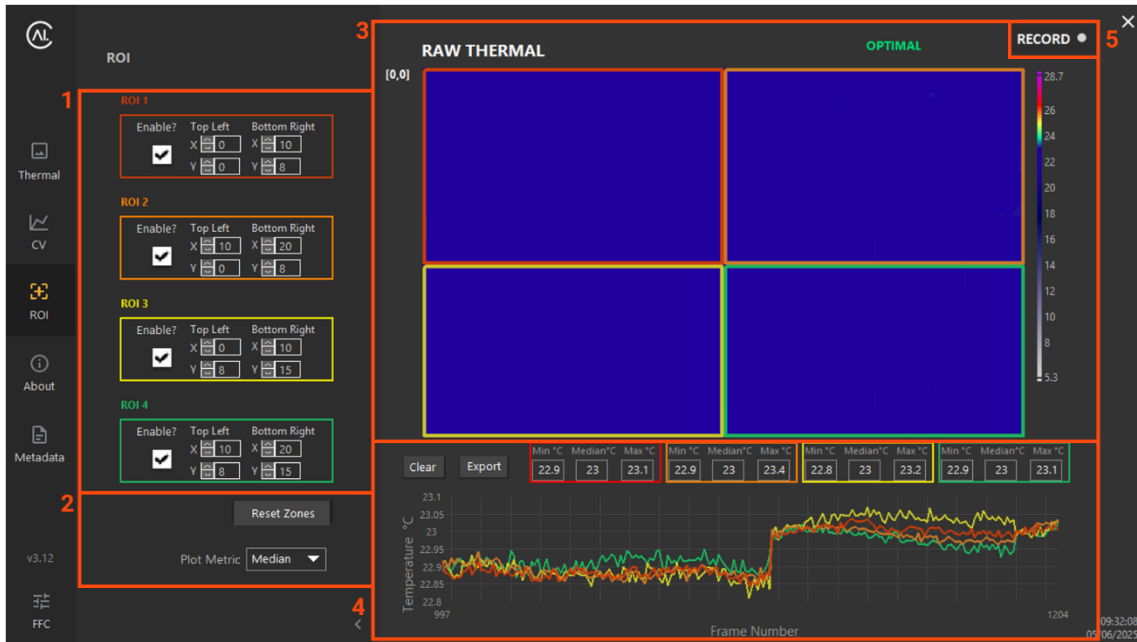

Figure 15 - Regions of Interest (ROI) tab in CTS Player

6.1 Menu 1: Region Configuration

Configuration Options for each of the regions:

Zone enable	Toggle to turn each of the four zones on or off.
ROI position and size	Position adjustments for the value of the top left and bottom right pixels of the zones. Defaults shown above in Figure 15.

6.2 Menu 2: Additional settings

Reset Zones	Resets size and location of the ROI zones back to the default value
Plot metric	Drop down which determines if the Maximum, Median or Minimum value for each ROI is plotted.

6.3 Menu 3: Visualisation

Thermal display containing the thermal data with the ROIs which have been enabled overlaid.

6.4 Menu 4: Thermal Data Plot

A time series plot of the thermal data seen in the visualiser. Only the ROIs enabled in menu 1 will be plotted. The parameter plotted for each of the ROIs is selected via the dropdown list in menu 2.

6.5 Menu 5: Record

Recorded data gets saved to the CTS Data folder on the Desktop.

7 About tab in CTS Player

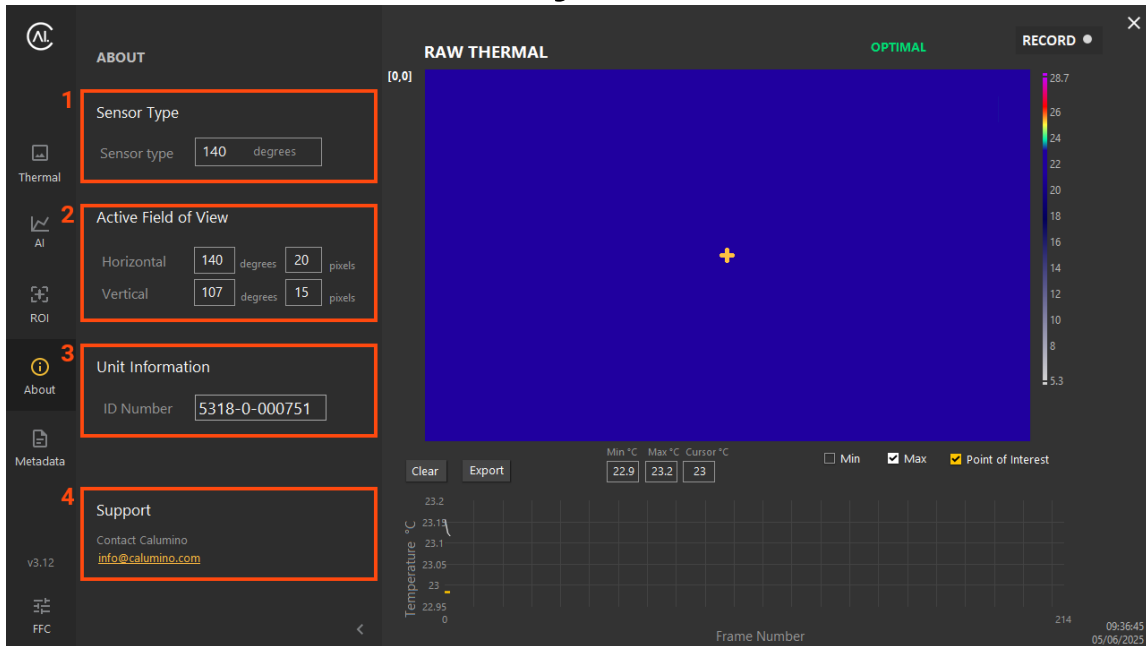

Figure 16 - About tab in CTS Player

Table 1 - Options in the About tab

1. Sensor Type	The FOV of the sensor in the EVK.
2. Active Field of View	The horizontal and vertical field of view (in degrees).
3. Unit Information	The unique serial number of the CTS.
4. Support	The contact information for Calumino.

8 Metadata tab in CTS Player

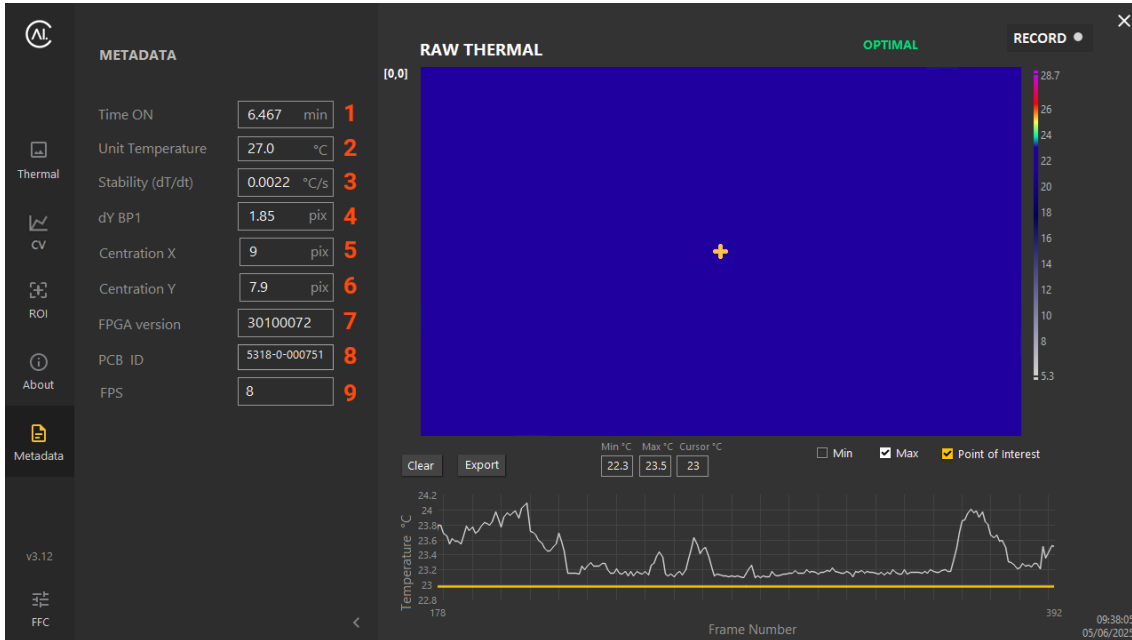

Figure 17 - Metadata tab in CTS Player

The Metadata tab contains additional information about the CTS.

Table 2 - Options in the Metadata tab.

1. Time ON:	The time in minutes that the EVK has been powered on.
2. Unit Temperature:	The internal CTS temperature.
3. Stability: The change in temperature over time of the CTS.	The contact information for Calumino.
4. dY BP1:	The blind pixel type, in CMOS pixels. This is a calibration parameter used by Calumino.
5. Centration (X):	The centre of the active area along the X axis.
6. Centration (Y):	The centre of the active area along the Y axis.
7. FPGA Version:	FPGA firmware version used in calibration.
8. PCB ID:	Unique Serial number of the CTS PCB.
9. FPS:	The frame rate in frames per second.

9 Utilities

9.1 Performing a Flat Field Correction (FFC)

The Flat Field Correction (FFC) utility can be used to reset pixel offsets to give a more accurate temperature reading.

To perform a Flat Field Correction operation, a flat surface with uniform color should be used and placed closely over the lens.

As an option, the temperature of the flat surface can be measured and input into the FFC utility. If used, this re-calibrates the absolute temperature measurement of each pixel.

When the FFC button is activated, a uniform temperature is assumed for all pixels, and the resultant delta offset values calculated.

The offset values will be applied to the future temperature readings, giving a more accurate absolute temperature profile across the array.

The offsets will be applied until the EVK is turned off. The information will not be retained.

Important:

Please ensure that the EVK's Field of View (FoV) is empty when launching the CTS Player, as it utilizes the initial frames as a reference frame for the computer vision system. This reference frame can also be reset while the CTS Player is active. To do so, ensure the EVK's FoV is unoccupied, then click "FFC" in the bottom-left corner and confirm the prompt in the subsequent pop-up.

When clicking on the FFC button, there will be a confirmation window presented.

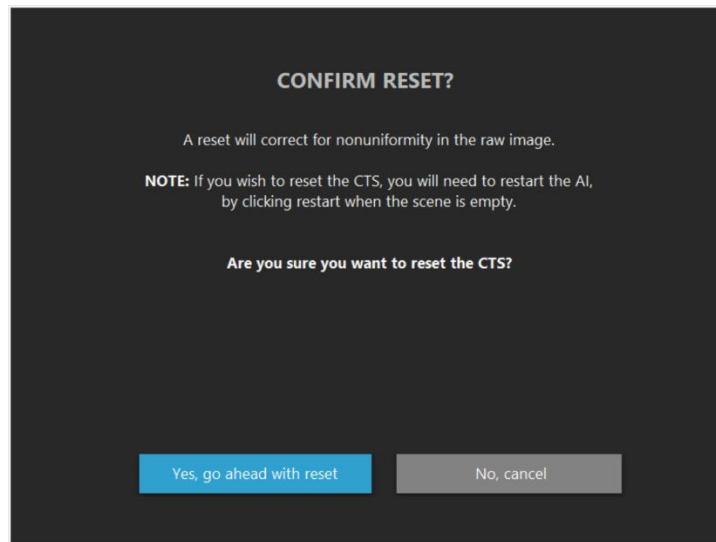

Figure 18 - Flat Field Correction confirmation window

Once the reset has been confirmed, the user will be presented with a second window which will allow them to configure the reset.

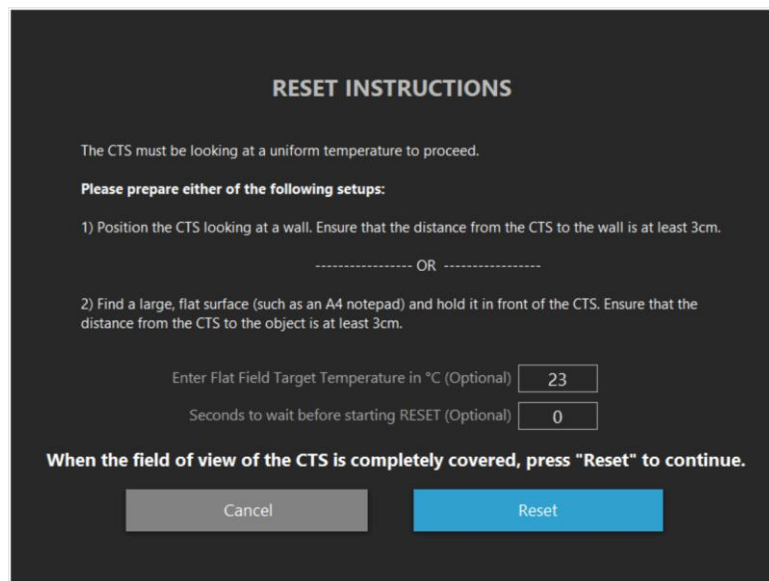

Figure 19 - Flat Field Correction Configuration window

This configuration includes optional target temperature and time (in seconds) to delay the FFC

10 Commercial Real Estate (CRE) Applications

The following set up is applicable for evaluating the sensor for use in commercial real estate applications.

Typically, in these applications, privacy is paramount. For this reason, some IR films have been provided with the EVK. If you would like to simulate the performance of a commercial product with an integrated CTS, Calumino recommends installing the provided film using the attached adhesive transfer tape.

10.1 Installing the IR film (optional)

For many, the privacy non-invasive nature of the Calumino sensor is of critical importance. For this reason, many products which have a Calumino sensor incorporated also take advantage of an infrared (IR) film covering the lens. This film allows infrared radiation to pass through whilst preventing the lens of the module from being seen.

To gain an understanding of how this IR film performs, several samples have been included in the evaluation kit. Please follow the installation instructions below:



Figure 20 - Installation procedure for the infrared film

1. Begin by peeling the backing tape from the IR film, starting from the tab.
2. Place the exposed adhesive on the top of the bossed section surrounding the lens, being careful not to touch the lens.
3. Continue pulling the adhesive backing from the film and pressing the film to the housing. This is best done working from top to bottom as shown above.

10.2 Installation for Occupancy Applications

Coverage Area

The EVK has a rectangular field of view, which results in different coverage areas depending on the mounting height.

Small Rooms (4m x 4m or smaller)

For small rooms, the orientation of the sensor does not matter, provided the edges of the field of view are parallel to the walls.

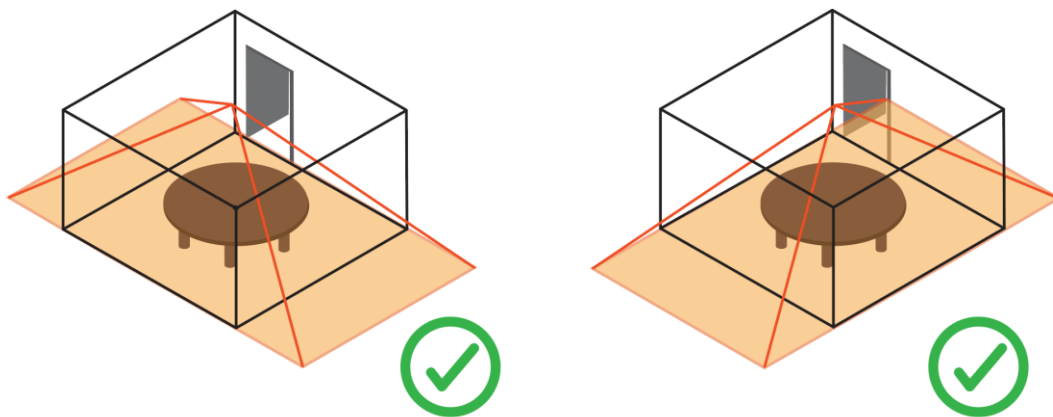

Figure 21 - Mounting orientation, small rooms

Large Rooms

For larger, rectangular rooms, ensure that the sensor is installed with the long axis directly parallel with the long axis of the room.

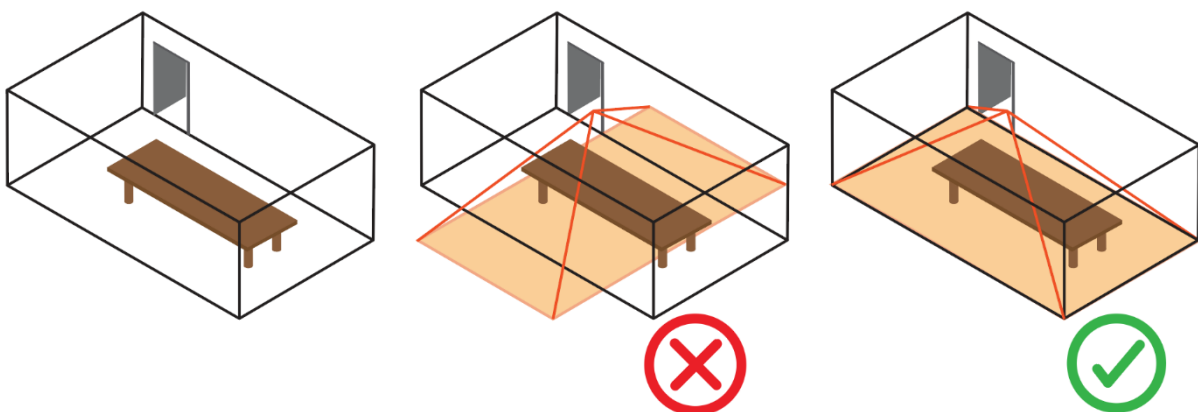

Figure 22 - Mounting orientation, large rooms

10.3 Installations for Door Counting Applications

For door counting applications, the edge of the field of view should be just outside of the door. This improves counting performance and accuracy.

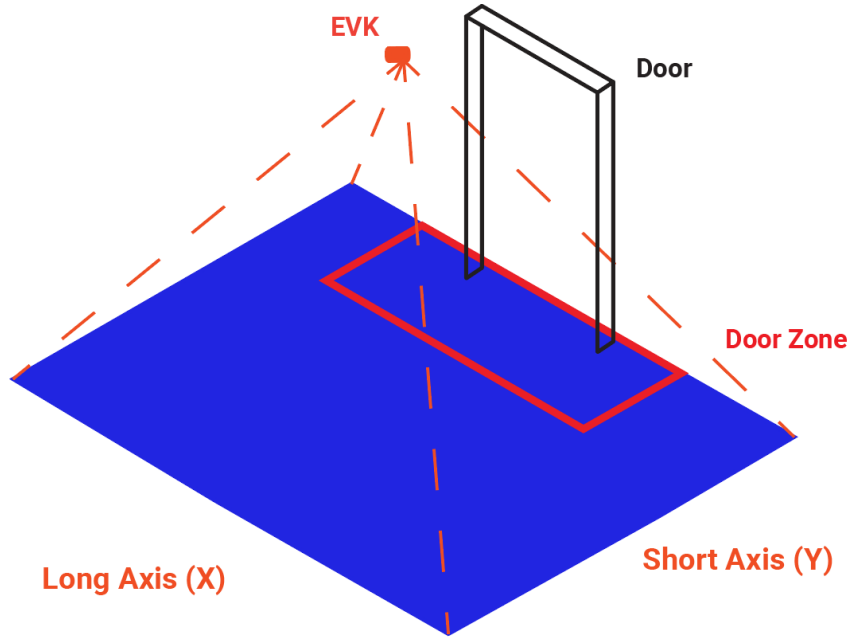

Figure 23 - Mounting orientation and approximate location for door counting

Table 3 - Sensor coverage area at mounting heights

Ceiling Height (Z) [m]	Distance from Door [m]	Long Axis (X) [m]	Short Axis (Y) [m]
2.5	1.0	6.0	4.0

10.4 Mounting the EVK to the Ceiling

Mounting using the adhesive strips



Figure 24 - Mounting the EVK to the ceiling using the adhesive strips provided

1. Peel off the backing paper from one of the adhesive strips and press it firmly to the back of the EVK.
Repeat with the remaining adhesive strip, pressing it to the ceiling.
Repeat one last time with the cable clip, approximately 200mm from the adhesive strip.
(This clip will prevent the weight of the cable pulling the EVK from the ceiling)
2. Press the two adhesive strips together firmly, ensuring they are secured to one another and that the EVK is pointing directly at the floor.

Mounting using the mounting bracket and a screw

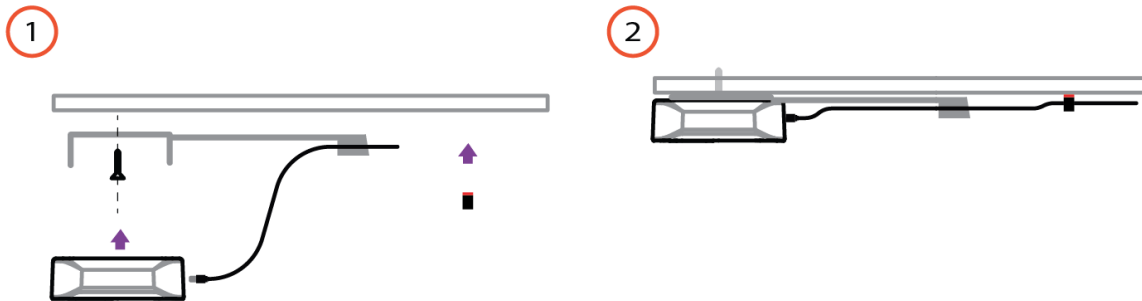

Figure 25 - Mounting the EVK using the mounting bracket

1. Fasten Part A of the tripod assembly (See Figure 26) to the ceiling through the countersunk hole using an appropriate screw.
Peel off the backing paper from the cable clip and press it to the ceiling approximately 200mm from the narrow end of the mounting bracket. (This clip will prevent the weight of the cable pulling the EVK from the ceiling)
2. Connect the USB cable to the EVK via the cable clip and the bottom of the mounting bracket.
Press the EVK onto the prongs of the bracket, allowing the friction fit and the cable clips to keep it securely in place.

11 Performing Commercial Real Estate Application Evaluation

11.1 Occupancy Evaluation

1. Place the EVK in the centre of the space in which the evaluation will take place.
2. Before conducting the evaluation, complete a CV reset with an empty room. This ensures the reference image used by the sensor for detections is accurate.
3. Enter the room after the CV reset timeout has concluded, observing the headcount increase.
4. Exit the room and observe the headcount return to zero.
5. Enter the room carrying a warm object such as a hot beverage or laptop, and the headcount should remain accurate, with the object not being classified as human.
6. Walk around the perimeter of the room to see detections across the complete FOV.
7. Gradually increase the number of people entering and occupying the room, simulating real-world scenarios such as business meetings. (Note the maximum number of people detected simultaneously is 21).

11.2 Door counting Evaluation

1. Ensure that the door zone size is sufficient for detecting people inside (Minimum 5 pixels deep in the direction of travel)
2. Reduce the likelihood of false detections by implementing exclusion zones in areas where reflections or other factors such as sunlight or cool air from fridges could affect counting.
3. Ensure the recommended mounting distance from the door is followed before evaluating the performance of the sensor.
4. Perform a CV reset with the field of view empty.
5. Counts will increase when a person crosses from inside the door zone into the rest of the FOV and decrease when a person leaves the FOV completely after having left through the door zone. See Calumino CRE Application Guide for more details.
6. Test the performance of a single person walking in and out at various speeds and directions and then repeat the process with two and then three people.

Note: Performance will vary when there are large temperature disparities either side of the door zone.

12 Industrial Monitoring Evaluation

12.1 Tripod installation:

Included with the EVK is a small tripod, allowing the EVK to be positioned facing towards assets that are to be monitored. It is constructed from two parts, A and B, seen below.

Installation of the EVK on the tripod can be achieved by following the four steps below:

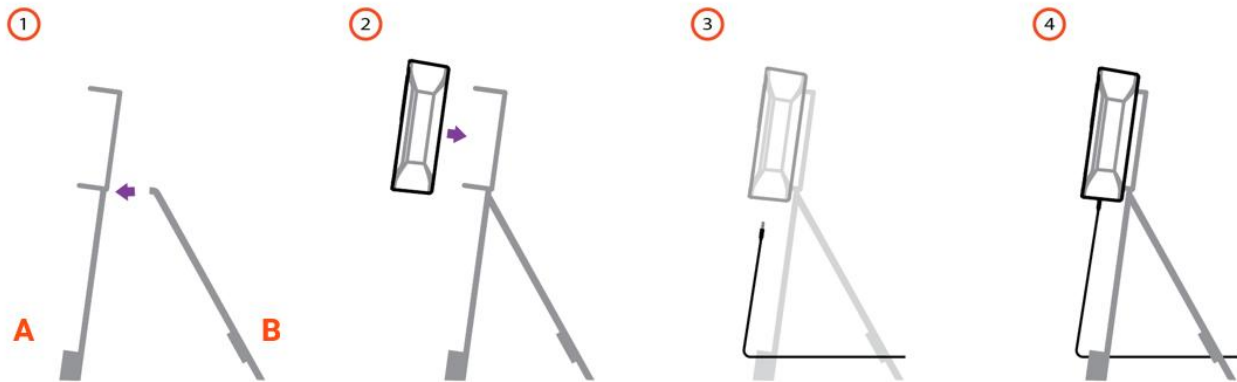

Figure 26 - Tripod installation instructions

1. Begin by pressing the hooks of Part B into Part A.
2. Press the EVK onto the four prongs of Part A.
3. Thread the USB-C end of the cable through both Part A and Part B, starting with Part B.
4. Connect the USB-C connector into the USB port on the bottom of the EVK and ensure that the cable is seated neatly in the cut-out in Part A.

12.2 Recording data in CTS Player for Region of Interest Application Testing:

- 12.2.1 Place the EVK on the tripod as instructed in Figure 26.
- 12.2.2 Place the EVK and tripod on a desk or stable surface facing towards the asset that is to be monitored.
- 12.2.3 Configure the ROI tab (Figure 15) such that the regions of interest are completely contained by one of the ROI binding boxes.
- 12.2.4 Once the setup is complete, a recording can be started by pressing the Record button (5) in Figure 15. Ensure that ROIs are enabled when selecting the data to be recorded from the CTS Player, by enabling the box labelled "Save ROI Data".

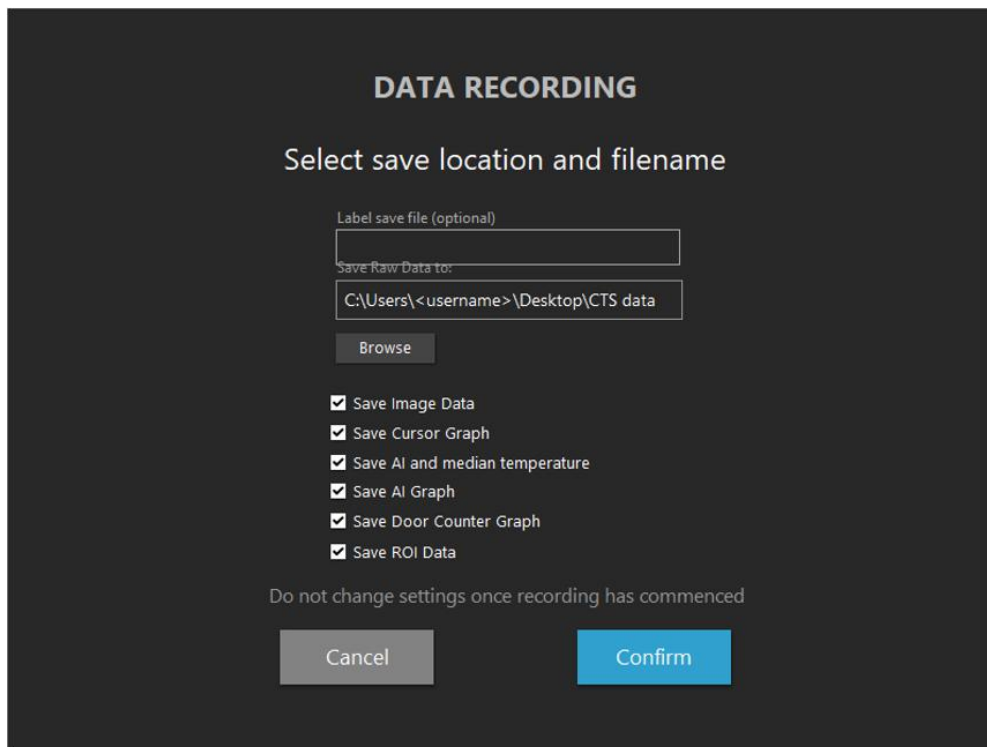

Figure 27 - Recording configuration window

- 12.2.5 Do not make any changes to the ROI binding boxes while a recording is in progress.
- 12.2.6 The recorded data will be found in the CTS Data folder on the Desktop.

13 Troubleshooting Guide

13.1 I am having issues installing the CTS Player

Possible cause: Windows cannot access all the files required to install the CTS Player due to them being contained in a ZIP folder.

Solution: This can be resolved by extracting out the contents of the installation folder and then attempting to re-run the setup.exe.

13.2 I get the following error "Ivanlys.dll: Resource Not Found" when running CTS Player

Possible cause: Computers that utilise AMD Ryzen Processors may raise this error when installing the CTS Player. This is related to a known LabVIEW 2018 bug pertaining to Intel's Math Kernel Library (MKL).

Solution: In this instance, please uninstall the CTS player and follow the steps at this [clickable link](#) to resolve. Once these steps have been completed, please re-install the CTS player as usual.

13.3 The thermal feed appears purple within the CV display

Possible cause: Rapidly changing thermal environment (i.e., covering and recovering the CTS rapidly with your hand) can cause the CV not to operate as intended.

Solution: This can be resolved by pressing the "Restart CV" button on the CV display screen (see Section 5.6). After a few seconds, the CV window should no longer appear purple.

13.4 When I attempt to connect to the unit, I get an "Error - NETD not found."

Please contact Calumino at support@calumino.com, and we will be able to provide you with the appropriate files to resolve this issue.

13.5 The program is frozen/unresponsive

Possible cause: Incorrectly installed CTS player.

Solution: Use the close program button in the top right to stop the program. If this is not possible, force quit using task manager. If this does not work, restart your computer and reopen the program.

Ensure the zip file was unzipped when you installed the program before running the setup.exe. It is recommended to uninstall the CTS player and reinstall using the unzipped setup.exe.

13.6 The drivers were not installed with CTS player

Possible cause: Relevant USB drivers were not installed during the CTS player installation process.

Solution: Download the relevant Zip folder from the downloads portal. Unzip the folder, and then right click the .sys files and select install. 3.2.4

Please refer to section 3.2.4.

13.7 The CV tab has frozen.

Possible cause: Relevant USB drivers were not installed during the CTS player installation process.

Solution: Use the Restart CV button. If this solution is not successful, unplug the EVK and plug it back in. This will completely restart the unit and begin functioning again. If the CTS player is still not responding, unplug the EVK, close the application and relaunch it and then plug the EVK back in.

Please refer to Section 3.2.4.

14 Revision History

Table 4- Document Revision Details

Revision	Date	Change
00	17 June 2025	Initial release
01	19 June 2025	Various minor changes to wording
02	26 August 2025	Updates to formatting and Styling. Changes relevant to CTS Player 3.15
03	07 November 2025	Updated to reflect naming convention changes